

DIN 125/A EN ISO 7089
DÜZ RONDELA
FLAT WASHER
FLACHE UNTERLEGSCHIEBE

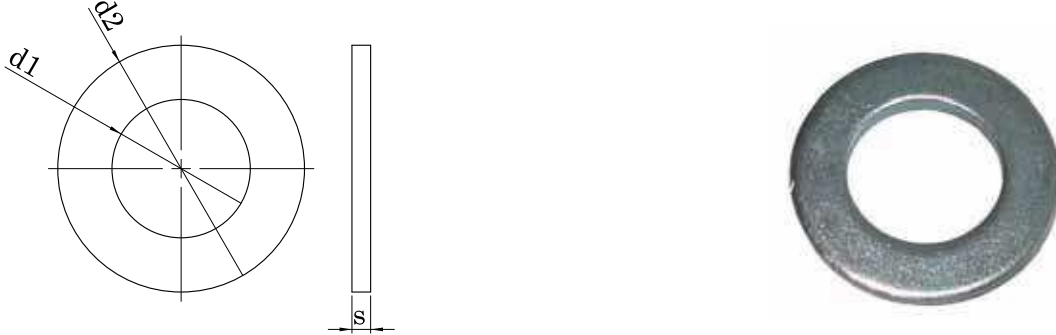

Technical Informations / Teknik Bilgiler

Thread size / Anma çapı (d)		M3	M4	M5	M6	M7	M8	M10	M12
d ₁	min.	3,20	4,30	5,30	6,40	7,40	8,40	10,50	13,00
	max.	3,38	4,48	5,48	6,62	7,62	8,62	10,77	13,27
d ₂	min.	6,64	8,64	9,64	11,57	13,57	15,57	19,48	23,48
	max.	7,00	9,00	10,00	12,00	14,00	16,00	20,00	24,00
s	min.	0,45	0,70	0,90	1,40	1,40	1,40	1,80	2,30
	max.	0,55	0,90	1,00	1,80	1,80	1,80	2,20	2,70
gr/p		0,12	0,31	0,44	1,02	1,39	1,83	3,57	6,27

Thread size / Anma çapı (d)		M14	M16	M18	M20	M22	M24	M26	M27
d ₁	min.	15,00	17,00	19,00	21,00	23,00	25,00	27	28,00
	max.	15,27	17,27	19,33	21,33	23,33	25,33	27,33	28,33
d ₂	min.	27,48	29,48	33,38	36,38	38,38	43,38	49,38	49,38
	max.	28,00	30,00	34,00	37,00	39,00	44,00	50,00	50
s	min.	2,30	2,70	2,70	2,70	2,70	3,70	3,70	3,70
	max.	2,70	3,30	3,30	3,30	3,30	4,30	4,30	4,30
gr/p	max.	8,62	11,30	14,70	17,20	18,30	32,30	43,70	42,30

Thread size / Anma çapı (d)		M28	M30	M32	M33	M36
d ₁	min.	29,00	31,00	33,00	34,00	37,00
	max.	29,33	31,39	33,62	34,62	37,62
d ₂	min.	49,38	55,26	58,80	58,80	64,80
	max.	50,00	56,00	60,00	60,00	66,00
s	min.	3,70	3,70	4,40	4,40	4,40
	max.	4,30	4,30	5,60	5,60	5,60
gr/p	max.	40,90	53,60	77,40	75,30	92,10

Values are given in millimeters. / Değerler milimetre olarak verilmiştir.

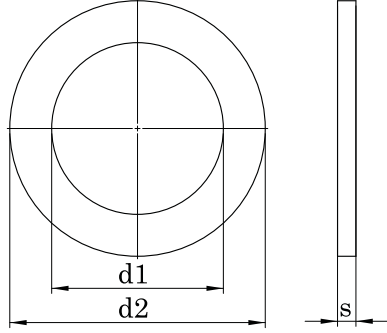
DIN 126 EN ISO 7091**DÜZ ALTI KÖŞE BAŞLI CIVATA VE SOMUNLAR İÇİN RONDELA****DESIGNED FOR USE WITH HEXAGON HEAD BOLTS AND NUTS****FLACHE UNTERLEGSCHİBE FÜR SECHSKANTSCHRAUBEN UND SECHSKANTMUTTERN****Technical Informations / Teknik Bilgiler**

Thread size / Anma çapı (d)	M5	M6	M7	M8	M10	M12	M14	M16	M18	M20
d1	5,50	6,60	7,60	9,00	11,00	14,00	16,00	18,00	20,00	22,00
d2	10,00	12,00	14,00	16,00	20,00	24,00	28,00	30,00	34,00	37,00
s	1,00	1,60	1,60	1,60	2,00	2,50	2,50	3,00	3,00	3,00
Diameter / Çap	5,00	6,00	7,00	8,00	10,00	12,00	14,00	16,00	18,00	20,00
gr/p	0,43	0,99	1,36	1,73	3,44	6,07	8,38	11,00	14,00	16,40

Thread size / Anma çapı (d)	22	24	27	30	33	36	39	42
d1	24,00	26,00	30,00	33,00	36,00	39,00	42,00	45,00
d2	39,00	44,00	50,00	56,00	60,00	66,00	72,00	78,00
s	3,00	4,00	4,00	4,00	5,00	5,00	6,00	7,00
Diameter / Çap	22,00	24,00	27,00	30,00	33,00	36,00	39,00	42,00
gr/p	17,50	31,10	39,50	50,50	71,00	87,40	127,00	175,00

Values are given in millimeters. / Değerler milimetre olarak verilmiştir.