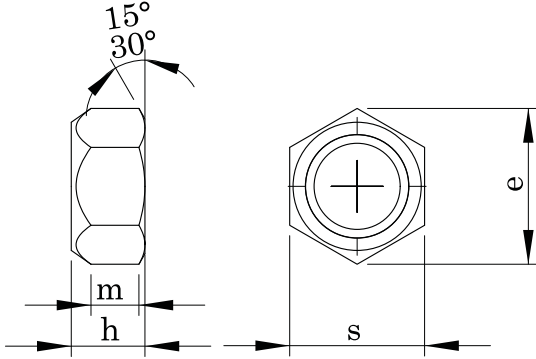

**DIN 980/V ISO 7042****SIKMALI ALTI KÖŞE SOMUN****PREVAILING TORQUE TYPE HEXAGON NUT , ALL METAL  
SICHERUNGSMUTTER (GANZMETALLMUTTER)****Technical Informations / Teknik Bilgiler**

Thread size / Anma çapı (d)		M6	M8	M10	M12	M14	M16	M18	M20
	P <sub>1</sub>		M8x1,00	M10x1,00	M12x1,50	M14x1,50	M16x1,50	M18x2,00	M20x1,50
Pitch / Diş adımı	P <sub>2</sub>			M10x1.25	M12x1,25			M18x1,50	M20x2,00
	P <sub>3</sub>	1,00	1,25	1,50	1,75	2,00	2,00	2,50	2,50
Flange dia / Flanş çapı	da min.	6,00	8,00	10,00	12,00	14,00	16,00	18,00	20,00
	da max.	6,75	8,75	10,80	13,00	15,10	17,30	19,50	21,60
Diagonal / Köşegen	dw min.	8,90	11,60	15,60	17,40	20,50	22,50	24,90	27,70
	e min.	11,05	14,38	18,90	21,10	24,49	26,75	29,56	32,95
Height / Yükseklik	h min.	5,70	7,50	9,00	11,00	12,00	14,00	16,00	18,00
	h max.	6,00	8,00	10,00	12,00	14,00	16,00	18,00	20,00
Head width / Anahtar ağız s	m	3,30	4,40	5,50	6,60	7,70	8,80	9,90	11,00
	s min.	9,78	12,73	16,73	18,67	21,67	23,67	26,16	29,16
	s max.	10,00	13,00	17,00	19,00	22,00	24,00	27,00	30,00
Weight / Ağırlık	gr/p	2,90	6,00	11,70	16,60	21,00	37,80	54,4	69,80

Values are given in millimeters. / Değerler milimetre olarak verilmiştir.