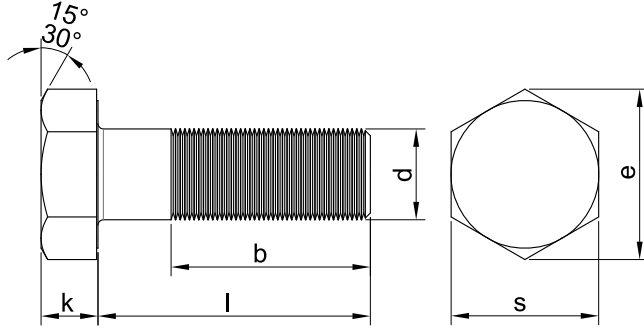

DIN 960 ISO 8765**ALTI KÖŞE BAŞLI İNCE DİŞ YARIM PASO CIVATA CL:8.8 - 10.9 - 12.9****HEXAGON HEAD BOLTS FINE THREADED****SECHSKANTSCHRAUBE MIT FEINGEWINDE****Technical Informations / Teknik Bilgiler**

Thread size / Anma çapı (d)		M 8	M 10	M 12	M 14	M 16	M 18	M 20	
Pitch / Diş adımı	P	1,00	1,25	1,00	1,50	1,25	1,50	1,50	1,50
Head height / Kafa yüksekliği	k	nominal	5,30	6,40	7,50	8,80	10,00	11,50	12,50
		min.	5,14	6,22	7,32	8,62	9,82	11,29	12,29
Head width/Anahtar ağızı	s	min.	5,45	6,58	7,68	8,98	10,18	11,72	12,72
		max.	12,73	16,73	18,73	21,67	23,67	26,67	29,67
Diagonal / Köşegen	e	min.	13,00	17,00	19,00	22,00	24,00	27,00	30,00
		max.	14,38	18,90	21,10	24,49	26,75	30,14	33,53
Thread length / Diş uzunluğu	b ¹ b ²	min.	22,00	26,00	30,00	34,00	38,00	42,00	46,00
		max.	28,00	32,00	36,00	40,00	44,00	48,00	52,00

b¹ for lengths l ≤ 125 mm.b² for lengths l >125 mm. ≤200 mm.b³ for lengths > 200 mm.

Thread size / Anma çapı (d)		M 8	M 10	M 12	M 14	M 16	M 18	M 20	
Length / Boy	min.	max.	Weight / Ağırlık gr/p						
30	29,58	30,42	17,10						
35	34,50	35,50	19,10	33,20	46,40				
40	39,50	40,50	21,10	36,30	50,80				
45	44,50	45,50	23,00	39,40	55,20	78,90	103,00		
50	49,50	50,50	25,00	42,50	59,60	84,50	111,00		
55	54,40	55,60	27,00	45,50	64,00	90,10	119,00	159,00	
60	59,40	60,60	28,90	48,60	68,40	95,70	127,00	169,00	215,00
65	64,40	65,60	30,90	51,70	72,80	101,00	135,00	179,00	228,00
70	69,40	70,60	32,90	54,70	77,20	107,00	143,00	189,00	240,00
75	74,40	75,60	34,80	57,80	81,60	112,00	151,00	199,00	253,00
80	79,40	80,60	36,80	60,90	86,00	118,00	159,00	209,00	265,00
85	84,30	85,70	38,80	63,90	90,40	123,00	167,00	219,00	277,00
90	89,30	90,70	40,70	68,00	94,80	129,00	175,00	229,00	290,00
95	94,30	95,70	42,70	71,10	99,20	134,00	183,00	239,00	302,00
100	99,30	100,70	44,70	74,20	104,00	140,00	191,00	249,00	314,00
110	109,30	110,70	48,60	80,30	113,00	152,00	217,00	269,00	339,00
120	119,30	120,70	52,70	86,40	122,00	164,00	233,00	289,00	363,00
130	129,20	130,80	54,00	92,50	131,00	176,00	249,00	308,00	387,00
140	139,20	140,80	58,00	98,60	140,00	188,00	265,00	328,00	412,00
150	149,20	150,80	62,00	105,00	149,00	200,00	281,00	348,00	437,00
160	159,20	160,80		111,00	158,00	212,00	296,00	368,00	461,00
170	169,20	170,80			167,00	224,00	312,00	388,00	486,00
180	179,20	180,80			176,00	236,00	328,00	408,00	510,00
190	189,10	190,90				248,00	344,00	428,00	535,00
200	199,10	200,90				260,00	360,00	448,00	560,00

Values are given in millimeters. / Değerler milimetre olarak verilmiştir.

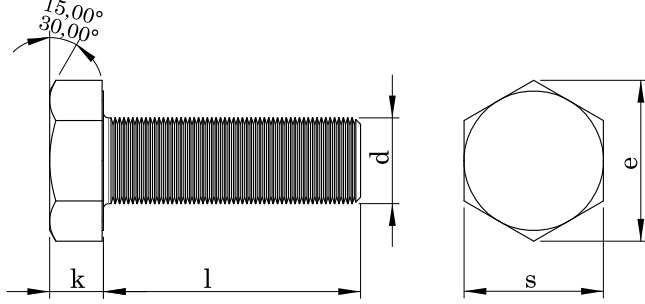
DIN 961 ISO 8676**ALTI KÖŞE BAŞLI İNCE DİŞ TAM PASO CIVATA CL:8.8 - 10.9 - 12.9**
HEXAGON HEAD BOLTS FINE THREADED UP TO HEAD
SECHSKANTSCHRAUBE MIT FEINGEWINDE BIS KOPF**Technical Informations / Teknik Bilgiler**

Thread size / Anma çapı (d)		M8	M10	M12	M14	M16	M18	M20		
Pitch / Diş adımı	P	1,00	1,00	1,25	1,50	1,25	1,50	1,50	1,50	2,00
Head height / Kafa yüksekliği k	nominal	5,30	6,40	7,50	8,80	10,00	11,50	12,50		
	min.	5,15	6,22	7,32	8,62	9,82	11,29	12,29		
	max.	5,45	6,58	7,68	8,98	10,18	11,72	12,72		
Head width / Anahtar ağızı	s	min.	12,73	15,73	17,73	20,67	23,67	26,67	29,67	
	max.	13,00	17,00	19,00	22,00	24,00	27,00	30,00		
Diagonal / Köşegen	e	min.	14,38	18,90	21,10	24,49	26,75	30,14	33,53	

b¹ for lengths l ≤ 125 mm.b² for lengths l >125 mm. ≤200 mm.b³ for lengths > 200 mm.

Thread size / Anma çapı (d)		M8	M10	M12	M14	M16	M18	M20	
Length / Boy (l)	min.								
	max.								
		Weight / Ağırlık gr/p							
20	19,58	20,42	12,40	23,50	32,90	48,70	64,50	90,00	118,00
25	24,58	25,42	14,10	26,20	36,60	54,00	71,50	98,50	128,00
30	29,58	30,42	15,70	28,90	40,30	59,10	78,50	107,00	139,00
35	34,50	35,50	17,40	31,60	44,00	64,40	85,30	116,00	151,00
40	39,50	40,50	19,10	34,30	47,70	69,60	92,30	124,00	162,00
45	44,50	45,50	20,70	36,90	51,40	74,90	99,00	133,00	172,00
50	49,50	50,50	22,30	39,60	55,00	80,20	106,00	142,00	184,00
55	54,40	55,60	24,00	42,30	58,70	85,40	113,00	151,00	195,00
60	59,40	60,60	25,70	45,10	62,40	90,60	120,00	160,00	207,00
70	69,40	70,60	29,00	50,50	70,00	101,00	134,00	177,00	228,00
80	79,40	80,60	32,30	55,80	77,40	111,00	148,00	195,00	251,00
90	89,30	90,70	35,70	61,20	84,80	122,00	162,00	212,00	272,00
100	99,30	100,70	38,90	66,70	92,20	133,00	176,00	229,00	295,00
110	109,30	110,70	42,40	72,20	99,20	144,00	190,00	247,00	317,00
120	119,30	120,70	45,90	77,50	107,00	154,00	204,00	265,00	339,00
130	129,20	130,80		79,90	114,00	165,00	218,00	283,00	361,00
140	139,20	140,80		88,30	121,00	175,00	232,00	300,00	383,00
150	149,20	150,80		93,60	128,00	186,00	245,00	318,00	405,00

Values are given in millimeters. / Değerler milimetre olarak verilmiştir.